

## REDSTONE SERIES Injection Robot Arm

### General Specification

Power Source	Working Pressure	Max. Allowed Pressure	Drive System	Swivel
1ΦAC 220V±10V 50/60Hz	5Kgf/cm <sup>2</sup> 0.49 Mpa	7Kgf/cm <sup>2</sup> 0.7 Mpa	AC Servo Motor	90° Fixed Pneumatic

### Main Specification

Model	R700 IS/ID/WS/WD-S3/S5	R900 IS/ID/WS/WD-S3/S5	R1100 WS/WD-S3/S5	R1400 WS/WD-S3/S5
Power Capacity (KVA)	2.4	2.4	3.2	3.2
Recommended I.M.M. (ton)	50 – 200	200 – 350	300 – 450	550-800
Traverse Stroke (mm)	1500 (1800)	1500 (1800)	1800 (2000)	2200
Crosswise Stroke (mm)	I/W:S3:P:690/610 I/W:S5:P:550/460 R:560/460	I/W:S3:P:750/670 I/W:S5:P:590/500 R:600/500	S3:P:800 S5:P:600 R:600	S3:P:980 S5:P:780 R:780
Vertical Stroke (mm)	700	900	1100	1400
Max. Loading (kg)	5	5	12	12
Dry Take Out Time (s)	1.2	1.6	1.8	2.2
Dry Cycle Time (s)	4.5	5.5	6.5	8.1
Air Consumption (NL/cycle)	3	3	5	5
Net Weight (kg)	350 – 420	380 – 460	440 – 490	480 – 540

### Model Denote:

**P:** Product Arm, **R:** Runner Arm

**S:** Product Arm (Single Arm), **D:** Product Arm + Runner Arm (Double Arm)

Text in red is optional for extending traverse stroke

**I:** Single stage, **W:** Telescopic type

**S3:** 3 axis servo motor, **S5:** 5 axis servo motor

### Dimension

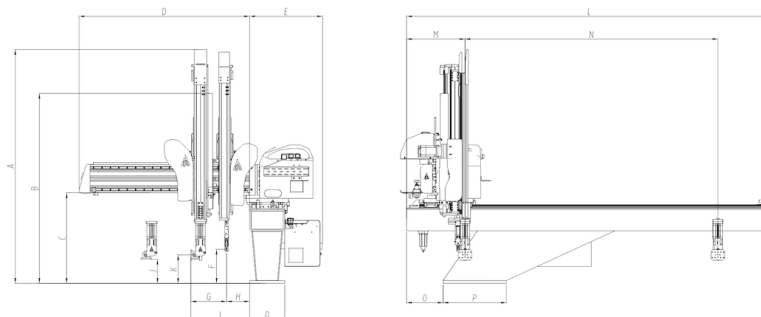

Model	A	B	C	D	E	F	G	H	I	J	K	L	M	N	O	P	Q
R700W	1610 (1410)		570	980	510	130	150	150	860 (840)	100	125 (200)	2085	300	1500	195	350	200
R900W	1820 (1510)			1060		(200)	(200)	(150)	950 (900)	(180)							
R1100W	(1770)	(1370)	650	1160		245	260	150	1050	180	200	2440	450	1800	260	450	250
R1400W	(1850)	(1460)		1340					1200			2840		2200			

\*Note: We reserve the right to change specifications without prior notice.